



SPECTRUM

SYSTEMENTWICKLUNG MICROELECTRONIC GMBH

MX.20xx - 8 bit transient recorder up to 200 MS/s

- PXI 3U / CompactPCI 3U format
- Up to 200 MS/s on one channel
- Up to 100 MS/s on two channels
- Simultaneous sampling on all channels
- 7 input ranges: ± 50 mV up to ± 5 V
- Up to 128 MSample memory
- FIFO mode for slower sampling rates
- Window and pulsewidth trigger
- Input offset up to $\pm 400\%$
- Synchronization possible
- Software SBench for Windows included
- Software SBench for Linux included



Product range overview

All boards of the MX.20xx series may use the on-board memory completely for the currently active number of channels.

Model	1 channel	2 channels	4 channels
MX.2020	50 MS/s	50 MS/s	
MX.2030	200 MS/s	100 MS/s	

Software/Drivers

A large number of drivers and examples are delivered with the board or are available as an option:

- Windows 98/ME/NT/2000/XP/Vista/7 drivers
- Linux 32bit and 64bit drivers
- SBench 5.x for Windows
- SBench 6.x Base version for Windows and Linux
- Visual C++/Borland C++ Builder examples
- Borland Delphi examples
- Microsoft Visual Basic examples
- Microsoft Excel examples
- LabWindows/CVI examples
- FlexPro support with SBench
- LabVIEW - drivers (as option)
- DASyLab - drivers (as option)
- MATLAB - drivers (as option)
- Agilent VEE - drivers (as option)

General Information

The two models of the MX.20xx series are designed for the fast and high quality data acquisition. Every of the up to four input channels has its own A/D converter and its own programmable input amplifier. This allows to record signals with 8 bit resolution without any phase delay between them. The inputs can be selected to one of seven input ranges by software and can be programmed to compensate an input offset of $\pm 400\%$ of the input range. The extremely large on-board memory allows long time recording even with highest sampling rates. A FIFO mode is also integrated on the board. This allows to record data continuously and to process it in the PC or to store it to hard disk.

Hardware block diagram

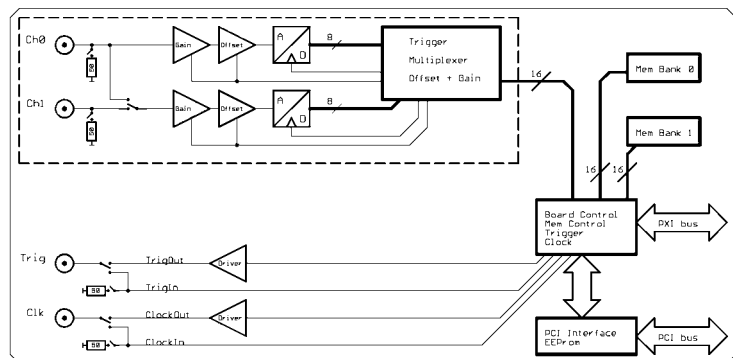

Software programmable parameters

sampling rate	1 kS/s to max sampling rate, external clock, ref clock, PXI clock
Input Range	± 50 mV, ± 100 mV, ± 200 mV, ± 500 mV, ± 1 V, ± 2 V, ± 5 V
Input impedance	50 Ohm / 1 MOhm
Input Offset	$\pm 400\%$ in steps of 1%
Clock mode	internal PLL, internal quartz, external, external divided, external reference clock, PXI reference clock
Clock impedance	50 Ohm / high impedance (> 4 kOhm)
Trigger impedance	50 Ohm / high impedance (> 4 kOhm)
Trigger mode	Channel, External, Software, Auto, Windows, Pulse, PXI Line[5..0], PXI Startrigger
Trigger level	1/64 to 63/64 of input range (6 bit)
Trigger edge	rising edge, falling edge or both edges
Trigger pulsewidth	1 to 255 samples in steps of 1 sample
Memory depth	64 up to installed memory in steps of 64
Posttrigger	64 up to 128 M in steps of 64
Multiple Recording segmentsize	64 up to installed memory / 2 in steps of 64

Application examples

LDA/PDA	Production test	Laboratory equipment
Radar	Spectroscopic	Test of mobile communication
Ultrasound	Medical equipment	

Possibilities and options

PXI bus

The PXI bus (PCI eXtension for instrumentation) offers a variety of additional normed possibilities for synchronising different components in one system. It is possible to connect several Spectrum cards with each other as well as to connect a Spectrum card with cards of other manufacturers.

PXI reference clock

The card is able to use the 10 MHz reference clock that is supplied by the PXI system. Enabled by software the PXI reference clock is feeded in the on-board PLL. This feature allows the cards to run with a fixed phase relation.

PXI trigger

The Spectrum cards support star trigger as well as the PXI trigger bus. using a simple software command one or more trigger lines can be used as trigger source. This feature allows the easy setup of OR connected triggers from different cards.

Input impedance

All inputs could individually be switched by software between 50 Ohm and 1 MOhm input impedance. If using fast signals and high sampling rates or have 50 Ohm cable impedance the use of the 50 Ohm termination is recommended to minimise noise and signal reflections. If using weak signal sources or standard probes the use of the 1 MOhm termination is helpful.

Ring buffer mode

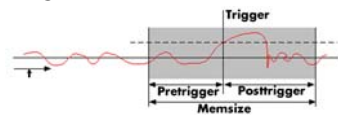

The ring buffer mode is the standard mode of all oscilloscope boards. Data is written in a ring memory of the board until a trigger event is

detected. After the event the posttrigger values are recorded. Because of this continuously recording into a ring buffer there are also samples prior to the trigger event visible: Pretrigger = Memsize - Posttrigger.

FIFO mode

The FIFO mode is designed for continuous data transfer between measurement board and PC memory (up to 100 MB /s) or hard disk (up to 50 MB/s). The control of the data stream is done automatically by the driver on interrupt request.

Channel trigger

The data acquisition boards offer a wide variety of trigger modes. Besides the standard signal checking for level and edge as known from oscilloscopes it's also possible to define a window trigger. All trigger modes can be combined with the pulsewidth trigger. This makes it possible to trigger on signal errors like too long or too short pulses.

External trigger I/O

All boards can be triggered using an external TTL signal. It's possible to use positive or negative edge also in combination with a programmable pulse width. An internally recognised trigger event can - when activated by software - be routed to the trigger connector to start external instruments.

Pulse width

Defines the minimum or maximum width that a trigger pulse must have to generate a trigger event. Pulse width can be combined with channel trigger, pattern trigger and external trigger.

Multiple Recording

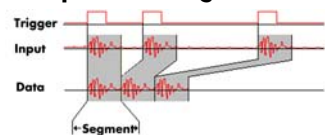

The Multiple Recording option allows the recording of several trigger events without restarting the hardware. With this option very fast repetition rates can be achieved. The

on-board memory is divided in several segments of same size. Each of them is filled with data if a trigger event occurs.

Gated Sampling

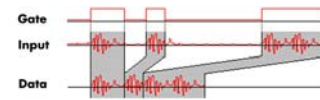

The Gated Sampling option allows data recording controlled by an external gate signal. Data is only recorded if the gate signal has a programmed level.

External clock I/O

Using a dedicated connector a sampling clock can be fed in from an external system. It's also possible to output the internally used sampling clock to synchronise external equipment to this clock.

Reference clock

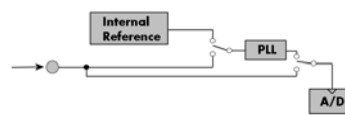

The option to use a precise external reference clock (normally 10 MHz) is necessary to synchronize the board for high-quality mea-

surements with external equipment (like a signal source). It's also possible to enhance the quality of the sampling clock in this way. The driver automatically generates the requested sampling clock from the fed in reference clock.

SBench 6

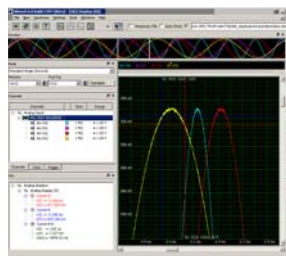

A base licence of SBench 6 the easy-to-use graphical operating software for the Spectrum cards is included in the delivery. Using the base licence it is possible to test the card and to show acquired data. There are also some basic measurement functions included in the base licence. The card comes with a demo license for the professional

version giving the user the opportunity to test the features of the professional version with the new hardware. Existing customers have the opportunity to request a demo license for the professional version at Spectrum. The professional version contains several new measurement functions, FFT, import and export (including MATLAB and ASCII) as well as the streaming modes. The data streaming modes allow to continuously acquire data to hard disk. SBench 6 has been optimized to handle data files of several GByte. More details on SBench 6 are found in the dedicated SBench 6 data sheet. The version 6 is running under Windows as well as under Linux (KDE and GNOME). A test version of SBench 6 is freely available in the internet. This test version will also operate with demo cards and can be tested as Professional version without any hardware installed.

Technical Data

Resolution	8 bit	Dimension	160 mm x 100 mm (Standard 3U)
Differential linearity error (ADC)	0.5 LSB typ.	Width (Standard)	1 slot
Integral linearity error (ADC)	0.5 LSB typ.	Analogue Connector	3 mm SMB male
Multi: Trigger to 1st sample delay	fixed	Overvoltage protection (range $\leq \pm 500$ mV)	± 5 V
Multi: Recovery (re-arm) time	< 20 samples	Overvoltage protection (range $> \pm 500$ mV)	± 50 V
Trigger accuracy 2/4 channel mode	1 Sample	Warm up time	10 minutes
Trigger accuracy 1 channel mode	2 Samples	Operating temperature	0°C - 50°C
Ext. clock: delay to internal clock	42 ns \pm 2 ns	Storage temperature	-10°C - 70°C
input signal with 50 ohm termination	max 5 V rms	Humidity	10% to 90%
Trigger output delay	1 Sample	Power consumption 3.3 V @ full speed	max. 1.43 A (4.7 Watt)
Input impedance	50 Ohm / 1 MOhm 25 pF	Power consumption 5 V @ full speed	max. 0.88 A (4.4 Watt)
Min internal clock	1 kS/s	Clock input: Standard TTL level	Low: -0.5 V > level < 0.8 V High: 2.0 V > level < 5.5 V Rising edge. Duty cycle: 50% \pm 5%
Min external clock	1 MS/s	Clock output	Standard TTL, capable of driving 50 Ohm Low < 0.4 V (@ 20 mA, max 64 mA) High > 2.4 V (@ -20 mA, max -48 mA)
Trigger input: Standard TTL level	Low: -0.5 > level < 0.8 V High: 2.0 V > level < 5.5 V Trigger pulse must be valid \geq 2 clock periods.		
Trigger output	Standard TTL, capable of driving 50 Ohm. Low < 0.4 V (@ 20 mA, max 64 mA) High > 2.4 V (@ -20 mA, max -48 mA) One positive edge after the first internal trigger		

Input range	± 50 mV	± 100 mV	± 200 mV	± 500 mV	± 1 V	± 2 V	± 5 V
Software programmable offset	± 200 mV	± 400 mV	± 800 mV	± 2 V	± 4 V	± 8 V	± 20 V
Offset error	< 1 LSB, adjustable by user						
Gain error	< 2 %	< 2 %	< 2 %	< 2 %	< 2 %	< 2 %	< 2 %
MX.2020: Noise (rms): 50 Ohm, 50 MS/s	< 1.0 LSB	< 1.0 LSB	< 1.0 LSB	< 1.0 LSB	< 1.0 LSB	< 1.0 LSB	< 1.0 LSB
MX.2030: Noise (rms): 50 Ohm, 100/200 MS/s	< 2.0 LSB	< 1.5 LSB	< 1.5 LSB	< 1.5 LSB	< 1.5 LSB	< 1.5 LSB	< 1.5 LSB
Crosstalk 5 MHz signal, ± 50 mV input, 50 Ohm	< 62 dB	< 62 dB	< 62 dB	< 62 dB	< 62 dB	< 62 dB	< 62 dB
	MX.2020	MX.2030					
max internal clock	50 MS/s	200 MS/s					
max external clock	50 MS/s	100 MS/s					
-3 dB bandwidth ± 50 mV	> 25 MHz	> 60 MHz					
-3 dB bandwidth $\geq \pm 100$ mV	> 25 MHz	> 90 MHz					

Dynamic Parameters

	MX.2020	MX.2030
Test - Samplerate	50 MS/s	100 MS/s
Test signal frequency	1 MHz	1 MHz
SNR (typ)	> 47.5 dB	> 45.9 dB
THD (typ)	< -52.5 dB	< -49.1 dB
SFDR (typ), incl harm.	> 57.0 dB	> 55.5 dB
SINAD (typ)	> 46.0 dB	> 44.2
ENOB (based on SINAD)	> 7.3	> 7.1

Dynamic parameters are measured at ± 1 V input range (if no other range is stated) and 50 Ohm termination with the samplerate specified in the table. Measured parameters are averaged 20 times to get typical values. Test signal is a pure sine wave of the specified frequency with > 99% amplitude. SNR and RMS noise parameters may differ depending on the quality of the used PC. SNR = Signal to Noise Ratio, THD = Total Harmonic Distortion, SFDR = Spurious Free Dynamic Range, SINAD = Signal Noise and Distortion, ENOB = Effective Number of Bits. For a detailed description please see application note 002.

Order information

Order No	Description	Order No	Description
MX2020	MX.2020 with 16 MSample memory and drivers/SBench 5.x	MX2xxx-32M	Option:32 MSample memory instead of 16 MSample standard mem
MX2030	MX.2030 with 16 MSample memory and drivers/SBench 5.x	MX2xxx-64M	Option:64 MSample memory instead of 16 MSample standard mem
		MX2xxx-128M	Option:128 MSample memory instead of 16 MSample standard
MX2xxx-mr	Option Multiple Recording: Memory segmentation	MX2xxx-up	Additional handling costs for later memory upgrade
MX2xxx-gs	Option Gated Sampling: Gate signal controls acquisition		
		MX20xx-dl	DASYLab driver for MX.20xx series
Cab-3f-9m-80	Adapter cable: SMB female to BNC male 80 cm	MX20xx-hp	VEE driver for MX.20xx series
Cab-3f-9m-200	Adapter cable: SMB female to BNC male 200 cm	MX20xx-lv	LabVIEW driver for MX.20xx series
Cab-3f-9f-80	Adapter cable: SMB female to BNC female 80 cm	MATLAB	MATLAB driver for all MX.xxxx, MX.xxxx and MX.xxxx series.
Cab-3f-9f-200	Adapter cable: SMB female to BNC female 200 cm		

Technical changes and printing errors possible